



GZ25G28CXXL-10X

25Gps SFP28 10km Dual CWDM Transceivers

PRODUCT FEATURES

- Operating data rate up to 25.78Gbps
- Up to 10km transmission distance
- High sensitivity Pin photodiode and TIA
- LC duplex connector
- Hot pluggable 20pin connector
- Low power consumption <1.2 W
- Single +3.3V±5% power supply
- Compliant with SFF-8472
- Fully RoHS Compliant
- Operating temperature range:
Commercial: 0°C to +70°C
External: -20°C to +80°C



Application

- 25GE BASE-LR Ethernet
- CPRI Option 10/eCPRI

DESCRIPTION

The GZ25G28CXXL-10 Transceiver is intended for 10km reach service from 24.33Gb/s to 25.78Gb/s CWDM C27~C37 single mode high-speed communications equipment where low-cost, extraordinary performance and reliability are essential. It consumes low power, operates base on 3.3V DC power supply and is offered in the industrial temperature range. They are compliant with SFP28 MSA, SFF-8431 and SFF-8432.

The low jitter and low bit error rate optical assembly features a C27~C37 DML laser transmitter and PIN/TIA receiver. It utilizes internal clock and data recovery (CDR) units on transmitter and the receiver chains for low jitter compliance. The differential AC coupled Tx

Shenzhen Guangzhi Communication Technology Co., LTD.

Production Address: 5th floor, Building 2, Peninsula Industrial Park, No. 3, Gangbian Tian Road, East Lake High-tech Zone, Wuhan Hubei Province, China.

Contact: Mr. Yang Tel.: +86-18607555895 E-mail: yanghan@optst.com

Website: www.optst.com

Document Number: OPTST-OP-055 A/0



and Rx data interfaces are CML compatible. The device is Class I laser safety compliant.

Absolute Maximum Ratings

Parameter	Symbol	Unit	Min	Max
Storage Temperature Range	T _s	°C	-40	85
Relative Humidity	RH	%	0	85
Supply Voltage	VCC	V	-0.5	4.0

Recommended Operating Conditions

Parameter	Symbol	Unit	Min	Typ	Max
Operating Case Temperature Range	T _c	°C	0		70
	T _c	°C	-20		80
Power Supply Voltage	V _{CC}	V	3.14	3.3	3.46
Bit Rate	BR	Gb/s		25.78	
Bit Error Ratio	BER				5*10 ⁻⁵
Max Supported Link Length	L	Km			10

Electric Ports Definition

Parameter	Symbol	Unit	Min	Typ	Max	Note
Transmitter						
Input Differential Impedance	R _{IN}	Ω		100		
Single-ended Data Input Swing	V _{IN}	mVp-p	90		450	
Transmit Disable Voltage	V _{DIS}	V	2		V _{CCHOST}	
Transmit Enable Voltage	V _{EN}	V	V _{EE}		V _{EE} +0.8	
Transmit Fault Assert Voltage	V _{FA}	V	2		V _{CCHOST}	
Transmit Fault De-Assert Voltage	V _{FDA}	V	V _{EE}		V _{EE} +0.4	
Receiver						
Single-ended Data Output Swing	V _{OD}	mVp-p	200		450	
LOS Fault	V _{LOSFT}	V	2		V _{CCHOST}	
LOS Normal	V _{LOSNR}	V	V _{EE}		V _{EE} +0.4	

Shenzhen Guangzhi Communication Technology Co., LTD.

Production Address: 5th floor, Building 2, Peninsula Industrial Park, No. 3, Gangbian Tian Road, East Lake High-tech Zone, Wuhan Hubei Province, China.

Contact: Mr. Yang Tel.: +86-18607555895 E-mail: yanghan@optst.com

Website: www.optst.com

Document Number: OPTST-OP-055 A/0



Optical Characteristics (Tc=0 to 70 °C and Vcc= 3.14 to 3.46V)

Parameter	Symbol	Unit	Min	Typ	Max	Note
Nominal Wavelength	λ	nm	1271,1291,1311,1331,1351,1371			
Wavelength Drift	$\Delta\lambda$	nm	-6.5		+6.5	
Average Output Power	Pav	dBm	0		7	
Spectral Width (-20dB)	σ	nm			1	
Extinction Ratio	ER	dB	3.5			
Side Mode Suppression Ratio	SMSR	dB	30			
Average Launch Power of OFF Transmitter	POFF	dBm			-30	
Relative Intensity Noise	RIN	dB/Hz			-130	
Center Wavelength	λ_c	nm	1260		1620	
Receiver Sensitivity	Sen	dBm			-13.8	1
Receiver Overload (OMA)	Pmax	dBm	2			
Optical Return Loss		dB			-26	
LOS Assert	LOSA	dBm	-30			
LOS De-Assert LOS	LOSD	dBm			-17	
LOS Hysteresis		dB	0.5			

Note1: Measured at 25.78125Gb/s, ER>3.5dBm, PRBS 2³¹-1 and BER better than or equal to 5E-5;

PIN Assignment

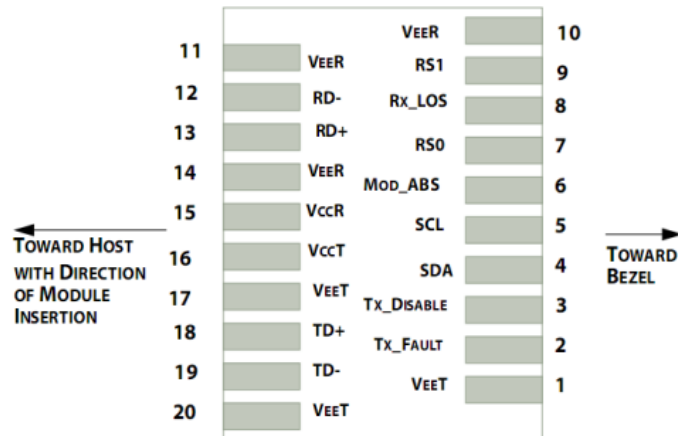

Figure 1.Pin function definitions

Shenzhen Guangzhi Communication Technology Co., LTD.

Production Address: 5th floor, Building 2, Peninsula Industrial Park, No. 3, Gangbian Tian Road, East Lake High-tech Zone, Wuhan Hubei Province, China.

Contact: Mr. Yang Tel.: +86-18607555895 E-mail: yanghan@optst.com

Website: www.optst.com

Document Number: OPTST-OP-055 A/0



Pin Number	Symbol	Name	Description
1,17,20	VeeT	Transmitter Signal Ground	Connected to signal ground on the host board.
2	TX Fault	Transmitter Fault Out (OC)	Module transmitter fault output.
3	TX Disable	Transmitter Disable In (LVTTTL)	Module transmitter disable control.
4	SDA	Module Definition Identifiers	Serial ID with SFF 8472 Diagnostics Module Definition pins should be pulled up to Host Vcc with 10 kΩ resistors.
5	SCL		
6	MOD-ABS		
7	RS0	Receiver Rate Select (LVTTTL) Transmitter Rate Select (LVTTTL)	Rate select 0(Rx):Low=CDR Bypass ; High=CDR Select
9	RS1		Rate select 1(Tx):Low=CDR Bypass ; High=CDR Select
8	LOS	Loss of Signal Out (OC)	Receiver loss of signal.
10,11,14	VeeR	Receiver Signal Ground	Connected to signal ground on the host board.
12	RD-	Receiver Negative DATA Out (CML)	Receiver inverted data output, internally AC coupled and terminated
13	RD+	Receiver Positive DATA Out (CML)	Receiver non-inverted data output, internally AC coupled and terminated.
15	VccR	Receiver Power Supply	Receiver Power 3.3V Supply.
16	VccT	Transmitter Power Supply	Transmitter Power 3.3V Supply.
18	TD+	Transmitter Positive DATA In (CML)	Transmitter non-inverted data input, internally AC coupled and terminated.
19	TD-	Transmitter Negative DATA In (CML)	Transmitter inverted data Input, internally AC coupled and terminated.

Digital Diagnostics Functions

As defined by the SFF-8472, Our SFP28 transceivers provide digital diagnostic functions via a 2-wire serial interface, which allows real-time access to the following operating parameters:

- Transceiver temperature
- Laser bias current
- Transmitted optical power
- Received optical power

Shenzhen Guangzhi Communication Technology Co., LTD.

Production Address: 5th floor, Building 2, Peninsula Industrial Park, No. 3, Gangbian Tian Road, East Lake High-tech Zone, Wuhan Hubei Province, China.

Contact: Mr. Yang Tel.: +86-18607555895 E-mail: yanghan@optst.com

Website: www.optst.com

Document Number: OPTST-OP-055 A/0



- Transceiver supply voltage

It also provides a sophisticated system of alarm and warning flags, which may be used to alert end-users when particular operating parameters are outside of a factory-set normal range. The operating and diagnostics information is monitored and reported by a Digital Diagnostics Transceiver Controller (DDTC) inside the transceiver, which is accessed through the 2-wire serial interface. The memories are organized as a series of 8-bit data words that can be addressed individually or sequentially. The 2-wire serial interface provides sequential or random access to the 8 bit parameters, addressed from 0x00h to the maximum address of the memory. For more detailed information, including memory map definitions, please refer the SFF-8472 documentation.

Digital Diagnostic Monitor Accuracy

The following characteristics are defined over recommended operating conditions

Parameter	Accuracy	Unit
Internally measured transceiver temperature	+/-3	deg.C
Internally measured transceiver supply voltage	+/-3	%
Measured Tx bias current	+/-10	%
Measured Tx output power	+/-3	dB
Measured Rx received average optical power	+/-3	dB

Shenzhen Guangzhi Communication Technology Co., LTD.

Production Address: 5th floor, Building 2, Peninsula Industrial Park, No. 3, Gangbian Tian Road, East Lake High-tech Zone, Wuhan Hubei Province, China.

Contact: Mr. Yang Tel.: +86-18607555895 E-mail: yanghan@optst.com

Website: www.optst.com

Document Number: OPTST-OP-055 A/0



Recommended Interface Circuit

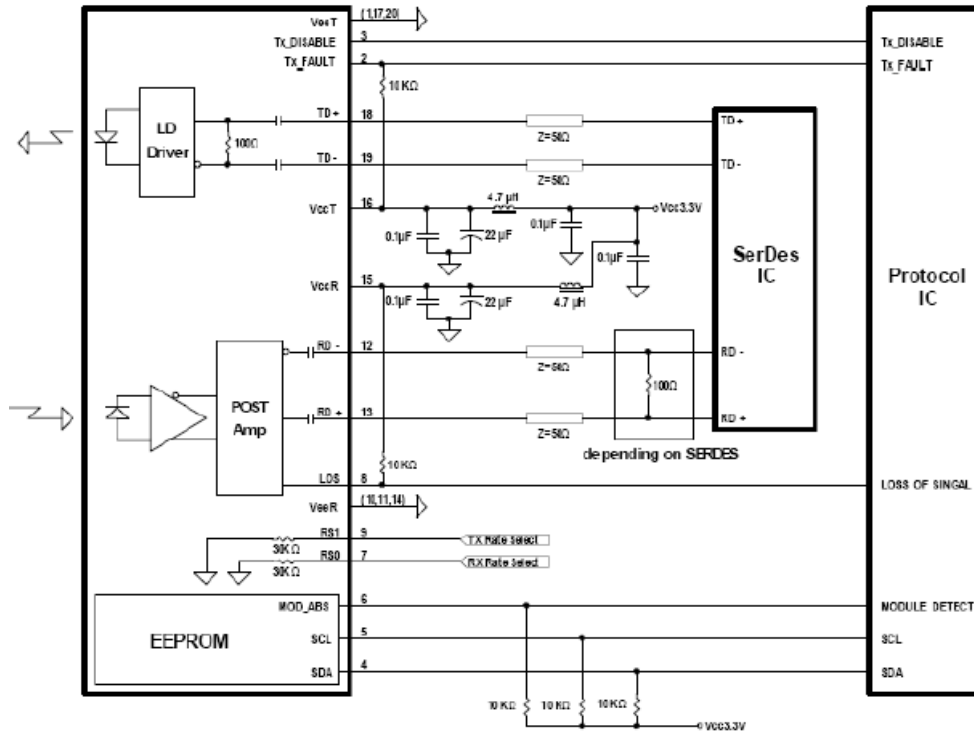

Figure 2. Typical application circuit

Shenzhen Guangzhi Communication Technology Co., LTD.

Production Address: 5th floor, Building 2, Peninsula Industrial Park, No. 3, Gangbian Tian Road, East Lake High-tech Zone, Wuhan Hubei Province, China.

Contact: Mr. Yang Tel.: +86-18607555895 E-mail: yanghan@optst.com

Website: www.optst.com

Document Number: OPTST-OP-055 A/0



Mechanical Dimensions

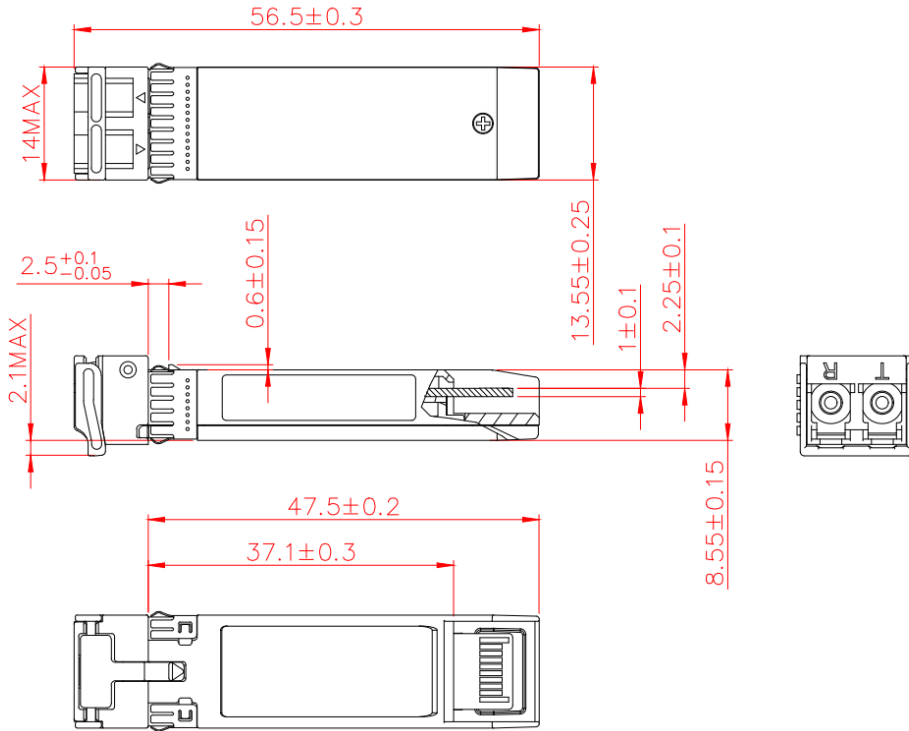

Figure 3. Module Mechanical Dimensions

Ordering information

Part. No	Specifications								
	Rate Gb/s	Tx	Tx WL nm	Po dBm	Rx	Sen. dBm	Temp °C	Reach Km	Other
GZ25G28CXXL-1 0	25.78	CWDM	1271~1371	0~7	PIN/TI A	<-13.8	0~70	10	RoHS
GZ25G28CXXL-1 0E	25.78	CWDM	1271~1371	0~7	PIN/TI A	<-13.8	-20~80	10	RoHS

Note: XX:27/29/31/33/35/37

Shenzhen Guangzhi Communication Technology Co., LTD.

Production Address: 5th floor, Building 2, Peninsula Industrial Park, No. 3, Gangbian Tian Road, East Lake High-tech Zone, Wuhan Hubei Province, China.

Contact: Mr. Yang Tel.: +86-18607555895 E-mail: yanghan@optst.com

Website: www.optst.com

Document Number: OPTST-OP-055 A/0



Warnings

Handling Precautions:

This device is susceptible to damage as a result of electrostatic discharge (ESD). A static free environment is highly recommended. Please follow guidelines according to proper ESD procedures.

Laser Safety:

Radiation emitted by laser devices can be dangerous to human eyes. Avoid eye exposure to direct or indirect radiation.

Notice:

The information provided on this page contains the product target specifications which are subject to change without notice.

Shenzhen Guangzhi Communication Technology Co., LTD.

Production Address: 5th floor, Building 2, Peninsula Industrial Park, No. 3, Gangbian Tian Road, East Lake High-tech Zone, Wuhan Hubei Province, China.

Contact: Mr. Yang Tel.: +86-18607555895 E-mail: yanghan@optst.com

Website: www.optst.com

Document Number: OPTST-OP-055 A/0